

cUL SYSTEM NO. FF-D-1001

FIRE-RATED JOINT THROUGH CONCRETE FLOOR ASSEMBLY

F AND FH-RATING = 2-HR.

FT AND FTH-RATING = 1-3/4 HR.

CLASS II MOVEMENT CAPABILITIES = 10% COMPRESSION OR EXTENSION

CROSS-SECTIONAL VIEW

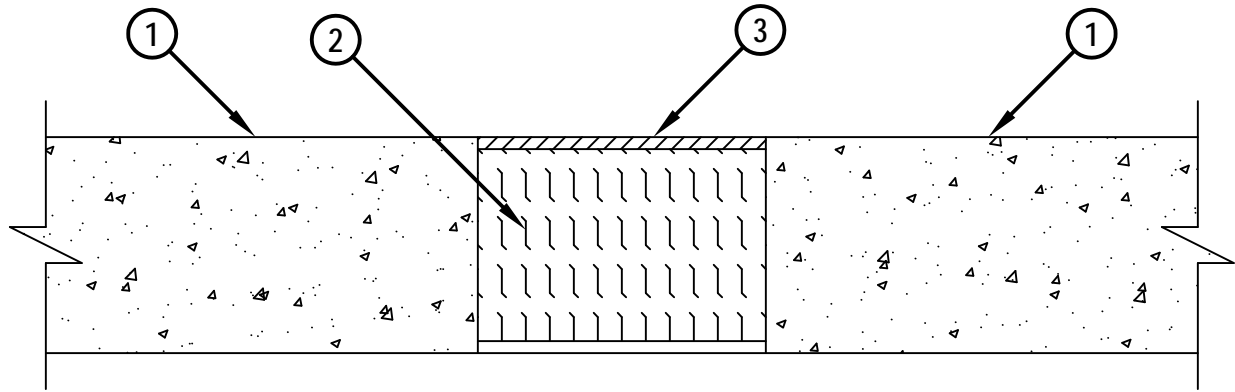

1. LIGHTWEIGHT OR NORMAL WEIGHT CONCRETE FLOOR ASSEMBLY (MINIMUM 4-1/2" THICK) (2-HR. FIRE-RATING).
2. MINIMUM 4" THICKNESS MINERAL WOOL SAFING (MIN. 4 PCF DENSITY) COMPRESSED 50% AND RECESSED TO ACCOMMODATE FIRESTOP SEALANT.
3. MINIMUM 1/4" DEPTH HILTI CP 604 SELF-LEVELING FIRESTOP SEALANT, HILTI CFS-S SIL GG FIRESTOP SILICONE SEALANT, OR HILTI CFS-S SIL SL FIRESTOP SILICONE SEALANT.

NOTE : MAXIMUM WIDTH OF JOINT = 6".



HILTI, Inc.
Tulsa, Oklahoma USA (800) 879-8000

Sheet	1 of 1
Scale	1/4" = 1"
Date	Dec. 23, 2013

Drawing No.

cUL
FFD1001b

Saving Lives through Innovation and Education



cUL FFD1001b.122313